

# Sentinel<sup>®</sup> XL

## Fume Hood Monitor

### Introduction

The Esco Sentinel<sup>®</sup> XL Fume Hood Monitor is designed to enhance hood safety by monitoring face velocity in real time. The system will generate an alarm if the face velocity drops lower than the low alarm set point or rises higher than the high alarm set point.

### Key Features:

- Specifically designed for Esco fume hoods.
- Easy to install.
- Simple to calibrate.
- Real time monitor of face velocity.
- Hassle-free self-test procedure.
- Audible (mutable) and visual alarm.
- Field adjustable face velocity alarm set point, to meet local regulatory and application requirements.
- Display units selectable between US (imperial) and metric.
- User-configurable PIN to restrict unauthorized configuration.
- Temperature compensated airflow sensor.
- Facilitates hood compliance with industry standards:
  - OSHA
  - NFPA
  - ANSI Z9.5
  - EN 14175
- Compatible with EFA, EFP, EFQ, EFI and EFF hoods.

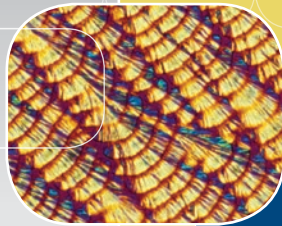

SXL-EFA

General Specifications, Sentinel XL	
Model	SXL-EFA
Control Panel Dimensions (W x H)	112 mm (4.4") x 80 mm (3.1")
Audible Alarm	85 dBA
Low Alarm Point	Default: 0.3 m/s (59 fpm) - adjustable
High Alarm Point	Default: 0.7 m/s (138 fpm) - adjustable
Electrical	100 - 240 VAC, 50/60 Hz
	Power Consumption
Indicator LEDs	SAFE (Green), UNSAFE (Red), MUTE (Yellow)
Night Setback Relay Input	SPST NO (normally open), 3.3 VDC Close relay to mute alarm (current: 3.3 mA)
Weight	2.5 kg (5.5 lbs)
Shipping Dimensions (W x D x H)	271 x 303 x 101 mm (10.7" x 12.0" x 4.0")



## Airflow Sensor (Mounts at Fume Hood Side Wall)

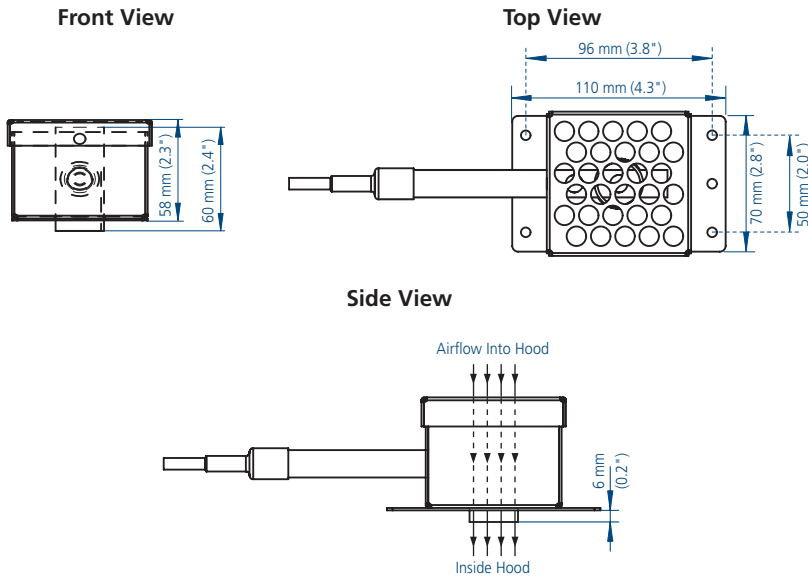

Velocity Sensor	
Velocity Range	0.2 - 0.9 m/s (39 - 177 fpm)
Required Input Voltage	12 VDC
Output Voltage Range	0.5 - 10 VDC
Power Consumption	0.6 W
Temperature Compensation Range	18°C - 30°C (64°F - 86°F)

## Sentinel XL User Interface Panel Technical Specifications (Mount on Fume Hood Side Post)

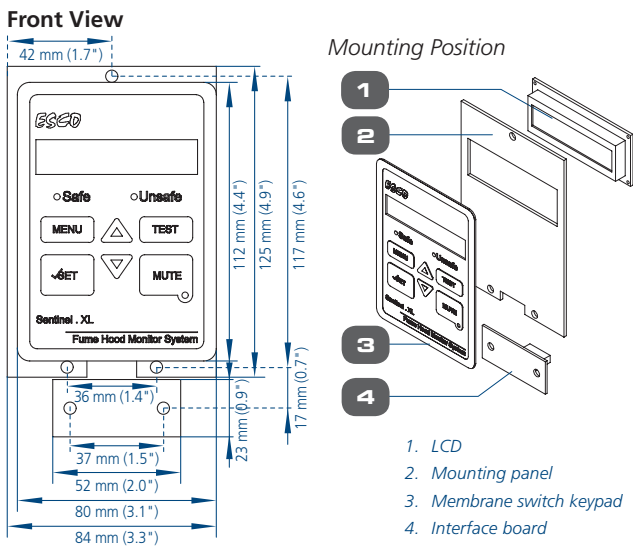

## Electrical Enclosure (Mounts at Top of Hood)

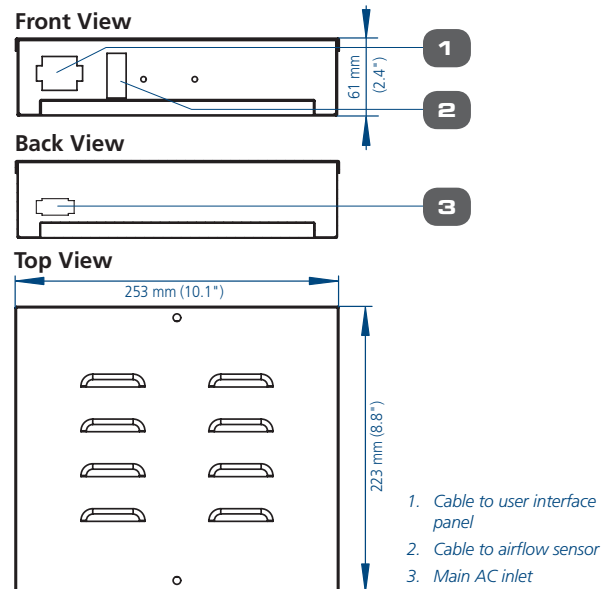

# ESCO

LIFESCIENCES GROUP

Esco Micro Pte. Ltd. • 21 Changi South Street 1 • Singapore 486 777  
 Tel +65 6542 0833 • Fax +65 6542 6920 • mail@escolifesciences.com  
 www.escolifesciences.com

Esco Technologies, Inc. • 903 Sheehy Drive, Suite F, Horsham, PA 19044, USA  
 Tel: +1 215-441-9661 • Fax 484-698-7757  
 eti.admin@escolifesciences.com

Esco Lifesciences Group Offices: Bangladesh | China | Denmark | Germany | Hong Kong | India | Indonesia | Italy | Japan | Lithuania | Malaysia | Myanmar | Philippines | Russia | Singapore | South Africa | South Korea | Taiwan | Thailand | UAE | UK | USA | Vietnam